

OSALE150

ERV - Energy Recovery Air Exchanger



Side Port Model



Top Port Model



CSA-C439-18

Features

Air flow and performance

- Fully adjustable air flow (150 cfm @ 0 in.w.g.).
- 63% sensible recovery effectiveness at 0 °C (32 °F) 30 L/s.

Voltage

- 120V, 60Hz, 1A.

Benefit

- Reduce heating demand in winter and cooling demand in summer.
- Whisper-quiet: factory calibrated and balanced.
- Easy installation and maintenance.
- Designed and manufactured in Canada to operate in variable climatic conditions.

Construction

- Door and housing in corrosion-resistant galvanized steel, 24-gauge, pre-painted neutral white.
- Convenient, screwless hinged door.
- Ultra-thin: 9 in. (229 mm).
- No drain required.
- Lightweight for ease of installation: 33 lb (15 kg).
- Port size: 5 in. (127 mm).
- Two configurations to optimize your space: Side Port or Top Port models.
- Reverse air flow configuration available as a factory installed option (-R). For further explanation, please refer to the document Normal and Reverse.
- Foam for ceiling installation for Top Port models only, available as a factory installed option (-F).
- Backdraft damper required on fresh air inlet (not supplied).

Motor

- Energy-efficient, sealed European motor with closed housing and automatic reset thermal protection.
- Balancing without flow keys. 100% electronic adjustment. Pressure ports integrated into the door for precise, easy balancing.

Energy recovery core

- High-efficiency 100% polymer core, extremely durable.
- Recovers both latent and sensible energy. (Heat and Humidity).
- Meets or exceeds ASHRAE 90.1-2010.
- Washable in soapy water to recover its full effectiveness without deterioration or contamination.
- Antimicrobial protection - ISO846.
- Avoid virus transfer - ASTM F-1671 tested.
- Zero crossflow contamination - Certified according to AHRI 1060.
- UL94 HB Flammability tested.

Control/timer

- Optional Decora-style wall-mounted control/timer (SA-LT15). INTERMITTENT (20-40) - CONTINUOUS - OFF - Timer (20-40-60 minutes).
- Furnace interconnect plug connector factory installed.

Installation

- Can be ceiling-mounted or suspended.
- Easily installed in the ceiling void or just below the fire-rated ceiling.
- Set of nylon suspension straps included for installation.
- Steel mounting plate for Top Port models only, available as an option (SA-P5R).

Setting

- Balance the unit using the supplied instruction named: Balancing.
- All the installer needs are the required flow rates, a manometer, and 5 minutes to adjust and balance the system.
- Simply specify the air flow rates for LOW SPEED and HIGH SPEED.
- The static pressure of the system should ideally be less than or equal to the static pressure indicated by the graph for HIGH SPEED.
- You don't have to worry about static pressure to limit air flow or adding flow keys as other devices. All you must do is provide ducting that doesn't limit maximum flow, and the unit's adjustments will allow you to fine-tune flow rates.

Warranty

- Motor 5-year. Other parts except filters and pre-filters 1-year.

Application

- The ideal solution for high-rise apartments and small to medium-size homes, when regulations do not require unit certification at -25°C (-13 °F).
- Purifies the air by expelling many pollutants, dust, and allergens to the outside, while ensuring an equivalent supply of fresh air in the home.

OSALE150

Side Port Model

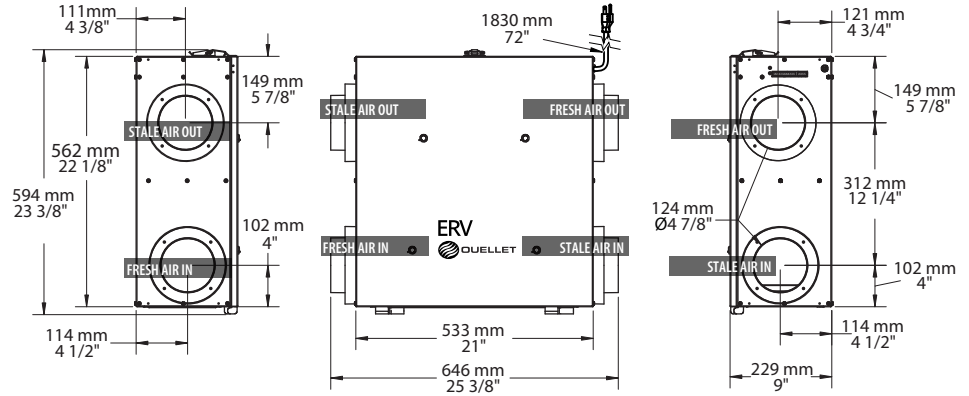
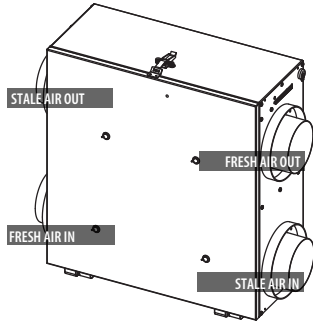

Top Port Model

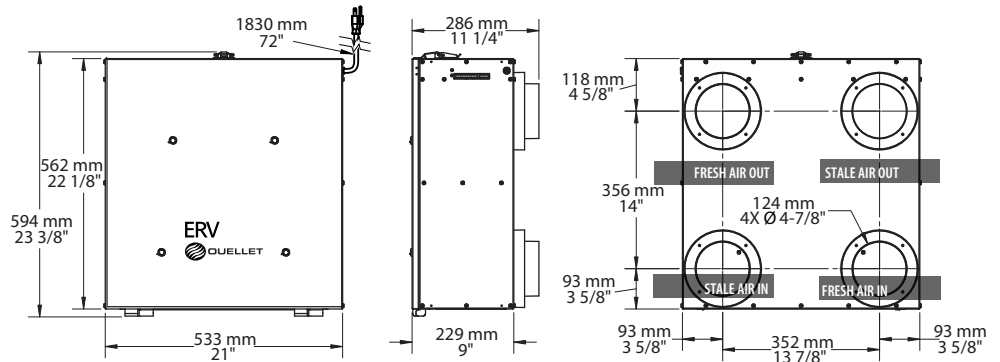
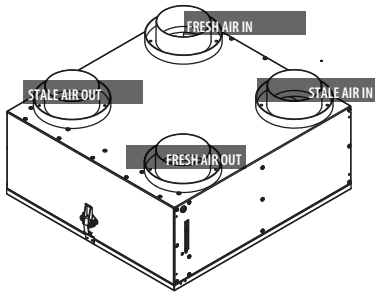

ERV OSALE150 - Curves at highest speed

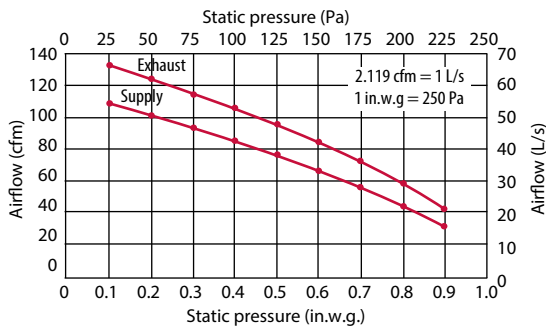

Energy ratings - HVI certified

Supply temperature	Air flow	Power	Sensible recovery (SRE) ¹	Adjusted Sensible Recovery	Latent recovery / moisture transfer
°C	°F	cfm	L/s	%	%
Heating					
0	32	53	25	54	60
0	32	64	30	62	63
0	32	104	49	96	59
Cooling					
35	95	53	25	57	49
			Total recovery efficiency	Adjusted total recovery efficiency	
					53

Models

Product #	cfm	Recirculation	SRE ¹ 0 °C (32 °F) 30 L/s	SRE ¹ -25 °C (-13 °F) 24 L/s	Port in. mm	Volts	Hertz	Amp.	Weight lb kg
ERV Energy recovery air exchanger 150 cfm (Side Port)									
OSALE150S	150	No	63%	No	5 127	120	60	1	33 15
ERV Energy recovery air exchanger 150 cfm (Top Port)									
OSALE150T	150	No	63%	No	5 127	120	60	1	33 15

¹ SRE: Sensible Recovery Effectiveness

Options

Product # Kit	Product # Factory installed*	Description
-	F	Foam for ceiling installation for Top Port models only
-	R	Reverse air flow
SA-P5R	-	Steel mounting plate for Top Port models only

Control

Product #	Description
SA-LT15	Decora wall-mounted control/timer for residential energy recovery air exchangers (ERV)



* For factory installed options, add the option number to the product number. See the Product Code section inside the front cover.