



180, 3<sup>rd</sup> Avenue, L'Islet, Quebec, G0R 2C0, CANADA  
 Tel.: (418) 247-3947, 1-800-463-7043 Fax: (418) 247-7801  
[www.ouellet.com](http://www.ouellet.com)

## INSTRUCTIONS OPH Series “3kW to 5kW”



### WARNING

When using electrical appliances, basic precautions should always be taken to reduce the risk of fire, electrical shock and injury, including the following.

Read carefully these instructions before installation, operation of the heater. Failure to adhere to the instructions could result in fire, electric shock, serious personal injury, and death or property damage. Review frequently for continuing safe operation and instruction of future users, if necessary.

## IMPORTANT INSTRUCTIONS

- 1- Read all instructions before installing or using this heater.
- 2- This heater is hot when in use. To avoid burns, do not let bare skin touch hot surfaces.
- 3- This heater is designed to be used in the space between a structural ceiling and a suspended ceiling, plenum space or plenum.
- 4- Do not operate any heater after it malfunctions. Disconnect power at service panel and have heater inspected by a reputable electrician before reusing.
- 5- Do not use outdoors.
- 6- Do not insert or allow foreign objects to enter any ventilation or exhaust opening as this may cause an electric shock or fire, or damage the heater.
- 7- To prevent a possible fire, do not block air intakes or exhaust in any way whatsoever.
- 8- To disconnect heater, operate internal disconnect switch or turn off power at main disconnect panel.
- 9- This heater has hot and arcing or sparking parts inside. Do not use it in areas where gasoline, paint, or flammable vapors or liquids are used or stored.
- 10- Use this heater only as described in this manual. Any other use not recommended by the manufacturer may cause fire, electric shock, or injury to persons.
- 11- The heater has been designed and certified for ambient heating only. The maximum ambient operating temperature is 30 °C (86 °F).
- 12- The heater is not designed for use in a humid environment where condensation may form on the device.
- 13- The thermostat should not be considered an infallible device in cases where maintaining a temperature is considered critical. Examples: Hazardous material storage, computer server room, etc. In these particular cases, it is imperative to add a monitoring system to avoid the consequences of a thermostat failure.

## SAVE THESE INSTRUCTIONS

## OPERATING INSTRUCTIONS

- 1- The heater must be properly installed before it is used.
- 2- Turn the power on at the circuit breaker panel.
- 3- Low voltage electronic wall thermostat:
  - Be sure to configure the thermostat in heating mode with fan.
  - Adjust the temperature set point in the thermostat.
- 4- Built-in thermostat with control knob optional.
  - To set thermostat at the desired temperature, follow these steps:
    - Set thermostat at maximum temperature (turn clockwise).
    - When the desired temperature is reached, turn the thermostat counter-clockwise slowly until you hear a click.
    - The thermostat will keep this room temperature.

### START UP

- On a call for heat from either the remote thermostat or the unit mounted thermostat the elements and fan will be energized.
- When the set thermostat is reached the elements will be deenergized.
- The fan will continue to run until the residual heat is removed from the heater. Then the fan will stop.

### OVERTEMPERATURE PROTECTION

- The motor and the electric heating elements are protected against overheat by an automatic reset thermal high-limit.
- A manual reset thermal high-limit is present for elements in case of failure of the automatic reset thermal high-limit.
- Cycling of either thermal high-limit indicates abnormal operation of the heater and must be fixed immediately.

### MANUAL RESEST HI-LIMIT RESUMING

- Disconnect all power supplies.
- Remove the side panel.
- Unscrew the cap and push the reset button on the hi-limit body inside the connections box to reset the hi-limit (Figure 6).
- Screw back the cap.
- Replace back the side panel.
- Turn the power back on.

### LUBRIFICATION OF MOTOR

The motor is a totally enclosed casing with ball bearings inside that doesn't need lubrication.

### MOTOR TRANSFORMER FUSES REPLACEMENT

- Disconnect all power supplies.
- Open the motor access panel (Figure 1).
- Change fuses and respect the current rating as well as the model required (Figure 1).
- Close the motor access panel.
- Turn the power back on.

## MAINTENANCE INSTRUCTIONS

- 1- Once a year, remove the dust accumulation inside the heater using a vacuum cleaner or compressed air.
- 2- Cleaning should be done while the heater is disconnected from the supply circuit. Wait until the housing and heating element cool before performing maintenance.
- 3- If the heater has an air filter, check the filter once a month. Use only a UL900 approved air filter of grade MERV 8 or less. Maximum actual dimensions must be 19 3/4 in. x 11 3/4 in. x 7/8 in. (501 mm x 298 mm x 22 mm).
- 4- Any other servicing should be performed by a qualified technician.
- 5- The motor is a totally enclosed casing with ball bearings inside that doesn't need lubrication.

## WARRANTY

Please refer to the product sheet at [www.ouellet.com](http://www.ouellet.com).

Figure 1

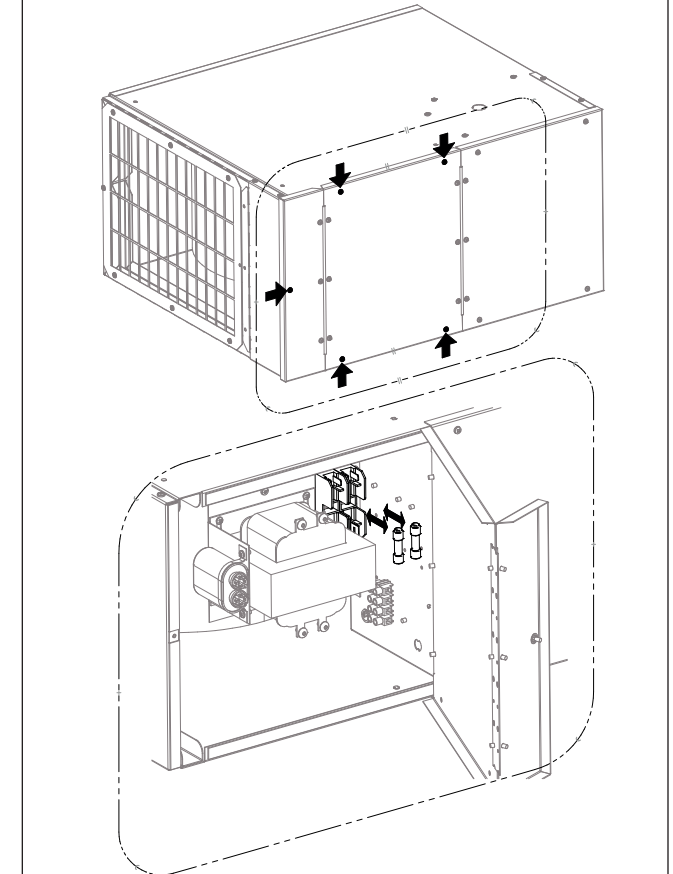

INS630-202210-03

# INSTALLATION INSTRUCTIONS

The installation of this heater must be executed by a qualified person, where required by law.

## CAUTION

- High temperature, risk of fire, keep electrical cords, drapery, furnishings, and other combustibles at least 36 in. (915 mm) from the front of the heater if free air discharge installation.
- In addition to ensuring that the clearance distances set out above are respected, ensure that the framing materials, insulation and finishing which are likely to be in contact with or close to the device can withstand temperatures of at least 90 °C (194 °F).
- To reduce the risk of fire, do not store or use gasoline or other flammable vapors and liquids in the vicinity of the heater.
- Do not block the air inlet or the air outlet of the heater.
- Disconnect all power supplies before working on any circuit.
- Put all covers back on heater before testing.
- If free air discharge installation, do not remove the inlet and outlet grilles of the heater.
- If installed on ductworks, make sure that the static pressure inside ductworks never exceed 0.2 in. (5 mm) WC.
- If installed on duckwork, make sure that the cross section area of the inlet duct is not less than 78 square inches (0.050 m<sup>2</sup>).

## INSTALLATION CONFIGURATIONS

### Free air discharge installation

- 1- This heater is designed to be used in the space between a structural ceiling and a suspended ceiling, plenum space or plenum.
- 2- Install the heater on horizontally in 1 of the 3 possible horizontal orientations (Figure 2).
- 3- Do not remove the inlet and outlet grilles.
- 4- Install the unit on adequate supports under the unit (non supplied), adapted to the load and with a minimum width of 1 1/4 in. (32 mm) (Figure 3).
- 5- Pay attention to the outlet air direction (Figure 3).
- 6- This heater is approved zero clearance but must be installed according to the minimum clearances indicated (Figure 4) to keep access to side panel.
- 7- Make sure to install supports to keep access to internal components for servicing and keep a minimum distance of 5 1/2 in. (140 mm) between the acces panel and supports. Take care to position the supports to keep access to the opening of the filter access panel (Figure 3).

### Installation on ductwork

- 1- This heater is designed to be used in the space between a structural ceiling and a suspended ceiling, plenum space or plenum.
- 2- Install the heater on horizontally in 1 of the 3 possible horizontal orientations or vertically with the air outlet upwards only (Figure 2).
- 3- Install the unit on adequate supports under the unit (non supplied), adapted to the load and with a minimum width of 1 1/4 in. (32 mm) (Figure 3).
- 4- This heater is approved zero clearance but must be installed according to the minimum clearances indicated (Figure 4) to keep access to side panel.
- 5- Make sure to install supports to keep access to internal components for servicing and keep a minimum distance of 5 1/2 in. (140 mm) between the access panel and supports. Take care to position the supports to keep access to the opening of the filter access panel (Figure 3).
- 6- Remove the outlet and/or inlet grilles.
- 7- Unbend outlet or/inlet flanges on the unit and adapt ductwork to the dimensions shown (Figure 5). Ductwork constructions must be done according to the NFPA 90B regulations.

## POWER SUPPLY CONNECTIONS

The wiring diagram is on the inside of the terminal compartment cover. Wire heater in accordance with local and national codes.

To make the power connection, remove the disconnect switch from its base by pushing the black "U" clip.

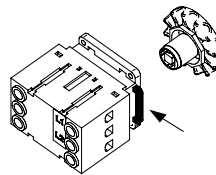

Once connected, reinstall the main switch on its base.

It is highly recommended to use watertight conduit hubs for power supply wires through the connections box.

## POWER SUPPLY CONNECTIONS

- The power supply may be single or three phase as shown on the nameplate. The wiring diagram is on the inside of the terminal compartment cover. Wire heater in accordance with local and national codes.
- It is highly recommended to use watertight conduit hubs for power supply wires through the connections box.

## TEST

- To test the unit heater, temporarily set thermostat to maximum temperature.
- Make sure that the fan rotates in the correct direction; airflow should be in the direction of the arrow such as indicated (Figure 3).

## OVERTEMPERATURE PROTECTION

- The motor and the electric heating elements are protected against overheat by an automatic reset thermal high-limit.
- A manual reset thermal high-limit is present for elements in case of failure of the automatic reset thermal high-limit.
- Cycling of either thermal high-limit indicates abnormal operation of the heater and must be fixed immediately.

## MANUAL RESEST HI-LIMIT RESUMING

- Disconnect all power supplies.
- Remove the side panel.
- Unscrew the cap and push the reset button on the hi-limit body inside the connections box to reset the hi-limit (Figure 6).
- Screw back the cap.
- Replace back the side panel.
- Turn the power back on.

## LUBRIFICATION OF MOTOR

The motor is a totally enclosed casing with ball bearings inside that doesn't need lubrication.

Figure 2

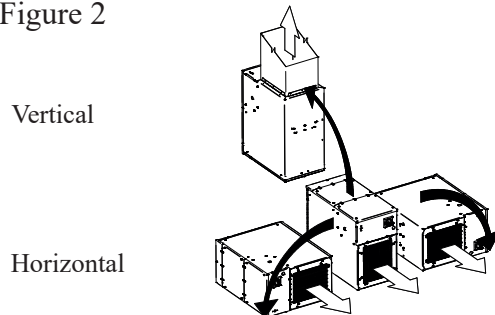

Figure 3

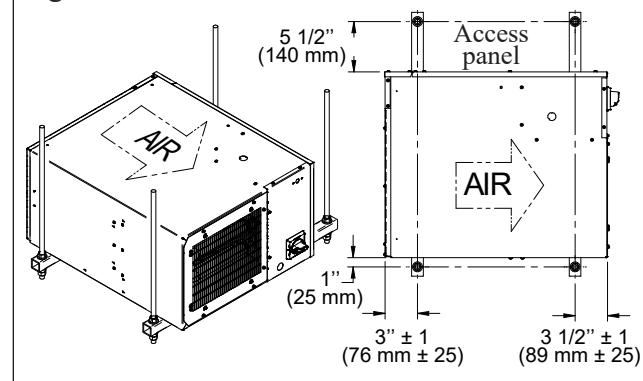

Figure 4

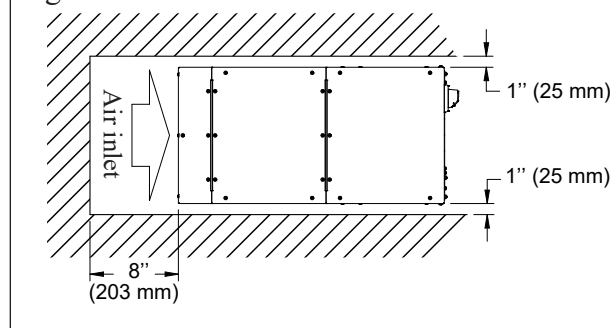

Figure 5

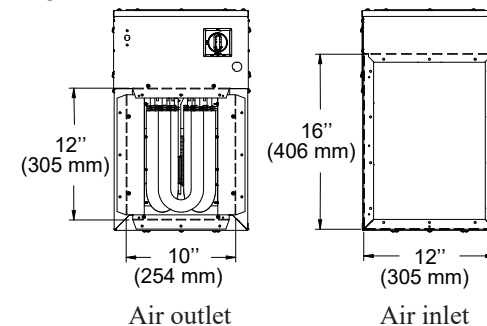

Figure 6

