



180, 3^e Avenue, L'Islet, Québec, G0R 2C0, CANADA
 Tél.: (418) 247-3947, 1-800-463-7043 Fax: (418) 247-7801
www.ouellet.com

INSTALLATION INSTRUCTIONS “OAV” Series

THE INSTALLATION MUST BE EXECUTED
 BY A QUALIFIED TECHNICIAN



LOCATION OF THE HEATER AND WALL THERMOSTAT

- To hang the heater (See table for positioning):
 Model 5 to 10kW: Use the 4 threaded holes (1/2”-13 UNC).
 Model 15 to 60kW: Use the 4 brackets.
- Connect the thermostat according to the wiring diagram inside of the control box cover.
- Connect sources to L1, L2 and if necessary L3 connectors. (See wiring diagram).
- The fan only switch must be connect on T1, T3 terminal. (See wiring diagram).
- Air inlet and outlet must be free from interferences such as columns, machinery and partition wall.
- Locate thermostat on interior partition wall or post (insulate from cold steel post). Install thermostat away from cold drafts, internal heat sources and from heater discharge.

POWER SUPPLY CONNECTIONS

The power supply may be single or three phases as shown on the nameplate. Wiring diagrams are inside of the control box cover. Wire heater in accordance with local and national codes.

TEST

- To test unit heater temporarily set thermostat at maximum temperature.
- Make sure that the fan rotates in the correct direction; airflow should be in the direction of the arrow such as indicated on the drawing.

KEEP THIS INSTRUCTION
 PAMPHLET FOR THE USER
 INS21-200207-04

LUBRICATION OF MOTOR

The motor includes sealed lubrication-free bearings.

OVERHEATING PROTECTION

The motor and the heating elements are protected against overheating by automatic thermal high-limits. Cycling of either high-limits is an indication of abnormal operation and should be corrected at once.

FAN DELAY

This unit is equipped with a fan delay which keeps the fan stopped at the beginning to let the heating element warm-up. The same fan delay keep the fan going when the heater is stopped to dispell residual heat.

ATTENTION

Basic precautions should always be followed to reduce the risk of fire, electric shock, and injury to persons.

- Read all instructions before using this heater.
- This heater is hot when in use. To avoid burns, do not let bare skin touch hot surfaces. Keep combustible materials at least 24 in. (610 mm) from the front of the heater.
- Minimum clearance from the walls and ceiling: 24 in. (610 mm).
- Install at least 8 ft. (2.5 m) from the floor.
- Do not use outdoors.
- Do not insert or allow foreign objects to enter any ventilation or exhaust opening as this may cause an electric shock or fire, or damage the heater.
- Do not block air intakes or exhaust in any manner.
- A heater has hot and arcing or sparking parts inside. Do not use it in areas where gasoline, paint, or flammable liquids are used or stored.
- Use this heater only as described in this manual. Any other use not recommended by the manufacturer may cause fire, electric shock, or injury to persons.

MAINTENANCE

Once a year, remove the dust accumulation inside the heater using a vacuum cleaner or compressed air. Cleaning should be done while the heater is disconnected from the supply circuit.

A qualified technician should perform any other servicing.

WARRANTY

Please refer to the product sheet at www.ouellet.com.

DIMENSIONS (without cone) & MINIMUM CLEARANCE

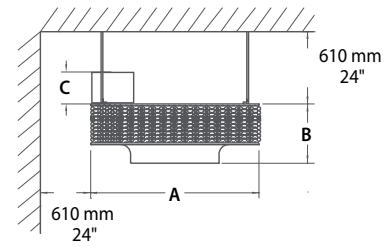

kW	A		B		C	
	mm	in.	mm	in.	mm	in.
5 to 10	587	23 1/8	203	8	176	6 15/16
15 to 30	768	30 1/4	310	12 3/16	170	6 11/16
40 to 60	1075	42 5/16	443	17 7/16	172	6 3/4

AIRFLOW DIRECTION

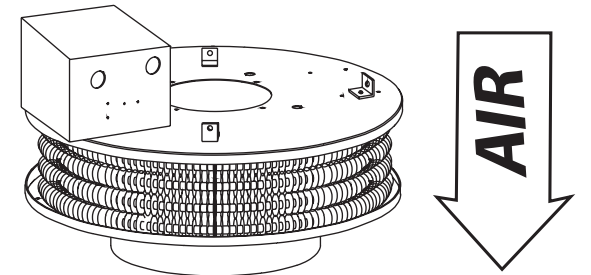

RECOMMENDED MAXIMUM MOUNTING HEIGHTS

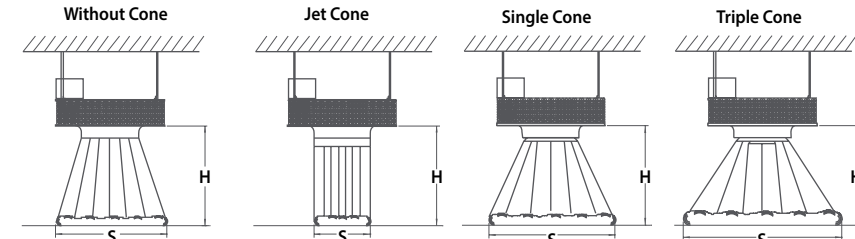

kW	Without Cone		Jet Cone				Single Cone				Triple Cone					
	H		S		H		S		H		S		H		S	
	m	ft.	m	ft.	m	ft.	m	ft.	m	ft.	m	ft.	m	ft.	m	ft.
5 to 10	3.7	12	5.8	19	4.9	16	6.1	20	2.5	8	6.9	22	3.1	10	9.5	31
15 to 30	5.5	18	8.5	28	6.7	22	8.5	28	3.7	12	10.0	33	4.3	14	13.2	43
40 to 60	8.3	27	13.0	42	9.1	30	11.9	40	4.3	14	11.8	38	6.1	20	15.5	50

POSITIONING OF THE 4 THREADED HOLES TO HAND MODEL 5 to 10kW

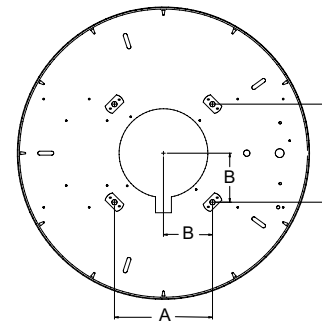

kW	A		B	
	mm	in.	mm	in.
5 to 10	196 ± 1.5	7 3/4 ± 1/16	98 ± 1.5	3 7/8 ± 1/16

POSITIONING OF THE 4 HOOKS TO HAND MODEL 15 to 60kW

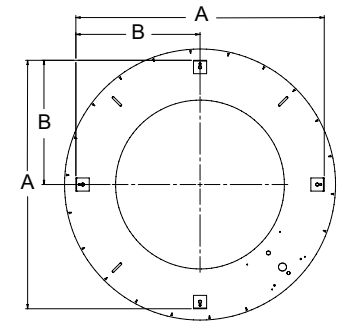

kW	A		B	
	mm	in.	mm	in.
15 to 30	639 ± 24	25 3/16 ± 15/16	320 ± 12	12 9/16 ± 1/2
40 to 60	986 ± 43	38 13/16 ± 1 11/16	493 ± 22	19 7/16 ± 7/8