

OPH Plenum Rated Unit Heater



*Product shown contain options that are not included with standard product. Please refer to the options chart.

Features

Color

- Standard: aluminum.

Finish

- Standard: epoxy/polyester powder paint.

Voltage

- 208V, 240V, 277V, 347V, 480V, 600V, 1 or 3-phase.

Construction

- 18 and 20-gauge steel.
- Adjustable louver for air flow direction available.
- Automatic reset and manual reset high-limit temperature control.
- One contactor per high-limit temperature control, on independent circuit.

Fan

- Direct drive, selectable speed squirrel-cage fan.
- Fan delay.

Motor

- Totally enclosed standard factory-lubricated motor.
- Thermally protected motor mounted in cold compartment.
- Constant torque motor (ECM), 1/3 HP max., 1050 rpm max., available

Heating element

- Three tubular heating elements with fins (for 3.1kW-5kW-7.5kW models).
- Six tubular heating elements with fins (for 10kW-12kW-15kW models).

Control

- Factory-installed contactor and 240/208V control circuit standard.*
- Factory-installed disconnect switch.
- 24V control circuit, with transformer available.*
- 120V control circuit with transformer available.*
- Built-in thermostat available.
- Optional 2-stage thermostat (for 10kW-12kW-15kW models).

Ouellet highly recommends to use a wall thermostat for greater comfort.

Any remote thermostat or relay must be connected to the heater control terminal block.

*Two stage heat with 2-stage thermostat available for 10kW to 15kW models.

Installation

- Horizontal mounting with free air discharge or ducted installation.
- Vertical mounting in the upwards air flow position with ducted installation only (3.1kW and 5kW models only).
- 80 °F (27 °C) maximum operating ambient temperature.
- Zero clearance approved when installed in concealed space.

Warranty

- 3-year warranty against defects.

Application

- This heater is designed to be used in the space between a structural ceiling and a suspended ceiling, plenum space or plenum.
- Crawl space, commercial vestibule, office, commercial building, warehouse, stairwell, underground parking.

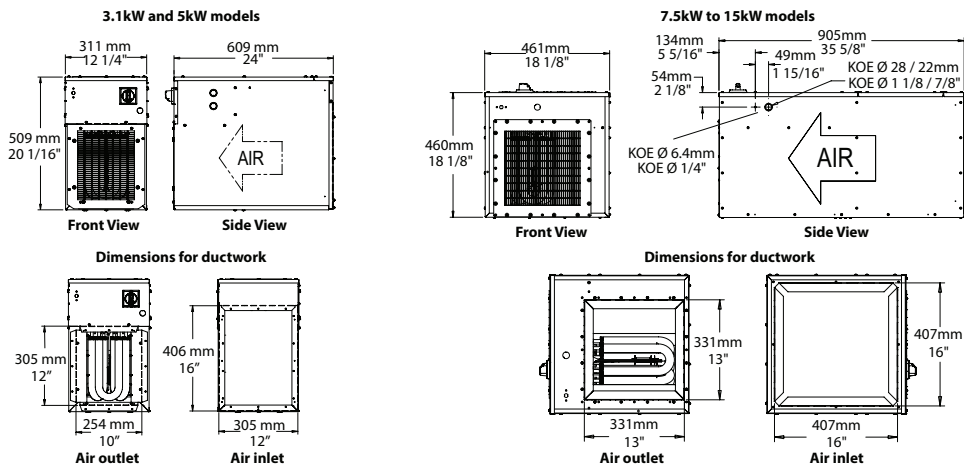

OPH

Models

Product #	Price	Volts	Phase	kW (BTU/hr)	cfm min. ¹		Temperature Rise ²		Motor	
					Low Speed	High Speed	°C	°F	HP	rpm
OPH03108AL-DIS40	2121.00	208	1	3.1 (10578)	430	460	12	22	1/3	1075
OPH03138AL-DIS40	2121.00	208	3	3.1 (10578)	430	460	12	22	1/3	1075
OPH03100AL-DIS40	2121.00	240	1	3.1 (10578)	430	460	12	22	1/3	1075
OPH03130AL-DIS40	2121.00	240	3	3.1 (10578)	430	460	12	22	1/3	1075
OPH03177AL-DIS40	2121.00	277	1	3.1 (10578)	430	460	12	22	1/3	1075
OPH03107AL-DIS40	2121.00	347	1	3.1 (10578)	430	460	12	22	1/3	1075
OPH03104AL-DIS40	2121.00	480	1	3.1 (10578)	430	460	12	22	1/3	1075
OPH03134AL-DIS40	2121.00	480	3	3.1 (10578)	430	460	12	22	1/3	1075
OPH03106AL-DIS40	2121.00	600	1	3.1 (10578)	430	460	12	22	1/3	1075
OPH03136AL-DIS40	2121.00	600	3	3.1 (10578)	430	460	12	22	1/3	1075
OPH05008AL-DIS40	2329.00	208	1	5 (17060)	430	460	21	37	1/3	1075
OPH05038AL-DIS40	2329.00	208	3	5 (17060)	430	460	21	37	1/3	1075
OPH05000AL-DIS40	2329.00	240	1	5 (17060)	430	460	21	37	1/3	1075
OPH05030AL-DIS40	2329.00	240	3	5 (17060)	430	460	21	37	1/3	1075
OPH05077AL-DIS40	2329.00	277	1	5 (17060)	430	460	21	37	1/3	1075
OPH05007AL-DIS40	2329.00	347	1	5 (17060)	430	460	21	37	1/3	1075
OPH05004AL-DIS40	2329.00	480	1	5 (17060)	430	460	21	37	1/3	1075
OPH05034AL-DIS40	2329.00	480	3	5 (17060)	430	460	21	37	1/3	1075
OPH05006AL-DIS40	2329.00	600	1	5 (17060)	430	460	21	37	1/3	1075
OPH05036AL-DIS40	2329.00	600	3	5 (17060)	430	460	21	37	1/3	1075
OPH07508AL-DIS80	2650.00	208	1	7.5 (25591)	1100	1200	14	25	1/3	1075
OPH07538AL-DIS40	2650.00	208	3	7.5 (25591)	1100	1200	14	25	1/3	1075
OPH07500AL-DIS40	2650.00	240	1	7.5 (25591)	1100	1200	14	25	1/3	1075
OPH07530AL-DIS40	2650.00	240	3	7.5 (25591)	1100	1200	14	25	1/3	1075
OPH07577AL-DIS40	2650.00	277	1	7.5 (25591)	1100	1200	14	25	1/3	1075
OPH07507AL-DIS40	2650.00	347	1	7.5 (25591)	1100	1200	14	25	1/3	1075
OPH07504AL-DIS40	2650.00	480	1	7.5 (25591)	1100	1200	14	25	1/3	1075
OPH07534AL-DIS40	2650.00	480	3	7.5 (25591)	1100	1200	14	25	1/3	1075
OPH07506AL-DIS40	2650.00	600	1	7.5 (25591)	1100	1200	14	25	1/3	1075
OPH07536AL-DIS40	2650.00	600	3	7.5 (25591)	1100	1200	14	25	1/3	1075
OPH10038AL-DIS40	2894.00	208	3	10 (34121)	1100	1200	18	32	1/3	1075
OPH10000AL-DIS80	2894.00	240	1	10 (34121)	1100	1200	18	32	1/3	1075
OPH10030AL-DIS40	2894.00	240	3	10 (34121)	1100	1200	18	32	1/3	1075
OPH10077AL-DIS80	2894.00	277	1	10 (34121)	1100	1200	18	32	1/3	1075
OPH10007AL-DIS40	2894.00	347	1	10 (34121)	1100	1200	18	32	1/3	1075
OPH10004AL-DIS40	2894.00	480	1	10 (34121)	1100	1200	18	32	1/3	1075
OPH10034AL-DIS40	2894.00	480	3	10 (34121)	1100	1200	18	32	1/3	1075
OPH10006AL-DIS40	2894.00	600	1	10 (34121)	1100	1200	18	32	1/3	1075
OPH10036AL-DIS40	2894.00	600	3	10 (34121)	1100	1200	18	32	1/3	1075
OPH12038AL-DIS80	2999.00	208	3	12 (40945)	1100	1200	22	40	1/3	1075
OPH12030AL-DIS40	2999.00	240	3	12 (40945)	1100	1200	22	40	1/3	1075
OPH12007AL-DIS80	2999.00	347	1	12 (40945)	1100	1200	22	40	1/3	1075
OPH12004AL-DIS40	2999.00	480	1	12 (40945)	1100	1200	22	40	1/3	1075
OPH12034AL-DIS40	2999.00	480	3	12 (40945)	1100	1200	22	40	1/3	1075
OPH12006AL-DIS40	2999.00	600	1	12 (40945)	1100	1200	22	40	1/3	1075
OPH12036AL-DIS40	2999.00	600	3	12 (40945)	1100	1200	22	40	1/3	1075
OPH15038AL-DIS80	3165.00	208	3	15 (51182)	1100	1200	27	49	1/3	1075
OPH15030AL-DIS80	3165.00	240	3	15 (51182)	1100	1200	27	49	1/3	1075
OPH15004AL-DIS40	3165.00	480	1	15 (51182)	1100	1200	27	49	1/3	1075
OPH15034AL-DIS40	3165.00	480	3	15 (51182)	1100	1200	27	49	1/3	1075
OPH15006AL-DIS40	3165.00	600	1	15 (51182)	1100	1200	27	49	1/3	1075
OPH15036AL-DIS40	3165.00	600	3	15 (51182)	1100	1200	27	49	1/3	1075

Options

Product # Kit	Product # Factory installed*	Price	Description
-	24	104.00	24V control circuit
-	120 ³	170.00	120V control circuit
-	OL	20.00	Power indicator light
-	ECM ⁴	434.00	Constant torque motor (ECM), 1/3 HP max., 1050 rpm max.
KIT-OPH-3-5KW-FI	FI	18.00	Pleated Air filter for 3-5kW models
KIT-OPH-3-5KW-FIW	FIW	336.00	Washable air filter for 3-5kW models
KIT-OPH-3-5KW-LR	LR	52.00	Louver kit for 3-5kW models
KIT-OPH-3-5KW-T	T	77.00	Built-in thermostat for 3-5kW models

Product # Kit	Product # Factory installed*	Price	Description
KIT-OPH-7-15KW-FI	FI	18.00	Pleated Air filter for 7-15kW models
KIT-OPH-7-15KW-FIW	FIW	336.00	Washable air filter for 7-15kW models
KIT-OPH-7-15KW-LR	LR	52.00	Louver kit for 7-15kW models
KIT-OPH-7-15KW-T	T	77.00	Built-in thermostat for 7-15kW models
KIT-OPH-T2S	T2S	149.00	Built-in 2-stage thermostat for 10-15kW models only

* For factory installed options, add the option number to the product number. See the **Product Code** section inside the front cover.

¹ Tested at 0.2" water column (static pressure).

² Tested at low speed.

³ With basic control or with the option «-120», the fan will work at low speed only.

⁴ Built-in transformer and contactor for 24V are required, add «-24» to the product number.

Standard color is aluminum.