

ORA-EC40

Commercial and Industrial Air Curtain



Horizontal mounting



Vertical mounting



FRICO

Features

Model

- Electric heat.
- No heat.

Color

- Stainless steel housing: white (RAL 9016, NCS S 0500-N).
- Grille, rear face and ends: grey (RAL 7046).
- Custom colors available upon request (RAL Chart).

Voltage

- 208V, 480V, 600V, 60 Hz.

Motor

- Very low operating costs can be achieved thanks to the combination of EC motors and Frico's unique fan geometry.

Construction

- External electronic board for easy connection and maintenance.
- Quick access to internal components via the maintenance hatch.
- High-limit temperature control with automatic reset.
- Integrated transformer for motor and control circuit (480V and 600V models)

Fan

- Squirrel-cage fans.

Element

- Element provides instant heat (electric heat model).

Control

- SIRe control system included.
- Door switch included.

- Compatible with a Building Management System.
- Personalize programming of the air curtain.

Installation

- Maximum height installation (horizontal mounted):
 - Surface mounted: 13.1 ft. (4 m) above floor.
 - Recessed: 13.1 ft. (4 m) above floor.
- Maximum width installation (vertical mounted):
 - 16 to 20 ft. (5 to 6 m) 2 units, 1 on each side.
- For vertical mounting, the air curtain must be used with the joining and vertical mounting kit PA4JK (not included).
- Design kit can be used for unobtrusive installations using concealed brackets, tubes and cables (not included).

Note: The recommended installation height may vary according to the installation conditions. Air curtains must be placed as near to the entrance as possible and cover the entire width.

Warranty

- 5-year warranty against defects.

Certification

- AMCA 210, 220 and 300 certified for performance and sound level, and meets the following Energy Standard for Buildings Code: ANSI/ASHRAE/IES standard 90.1.

Application

- Garage door, vestibule, commercial building, lobby, service door, hospital, store entrance.

ORA-EC40

Models

Volts (ph)	Product #	Price	kW Lo/Hi	Amp.	cfm	Max velocity (ft./min) ¹	dBA ²	Effective width of air stream		Weight	
								in.	mm	lb	kg
Surface-mounted											
Electric heat											
600 (3)	PAEC4010E12-600VNA	7508.00	4/12	15	1400	2560	80	38	960	104	47
600 (3)	PAEC4015E18-600VNA	9106.00	6/18	23	1950	2560	81	58	1470	137	62
600 (3)	PAEC4020E24-600VNA	13025.00	8/24	30	2800	2560	82	77	1960	185	84
600 (3)	PAEC4025E30-600VNA	14865.00	10/30	38	3300	2560	83	97	2470	234	106
480 (3)	PAEC4010E12-480VNA	7508.00	4/12	18	1400	2560	80	38	960	104	47
480 (3)	PAEC4015E18-480VNA	9106.00	6/18	27	1950	2560	81	58	1470	137	62
480 (3)	PAEC4020E24-480VNA	12349.00	8/24	35	2800	2560	82	77	1960	185	84
480 (3)	PAEC4025E30-480VNA	16064.00	10/30	45	3300	2560	83	97	2470	234	106
208 (3)	PAEC4010E10-208VNA	7222.00	4/10	31	1400	2560	80	38	960	93	42
208 (3)	PAEC4015E15-208VNA	8827.00	5/15	45	1950	2560	81	58	1470	126	57
208 (3)	PAEC4020E20-208VNA	12323.00	7/20	60	2800	2560	82	77	1960	172	78
No heat											
208 (1)	PAEC4010A-NA	6299.00	-	3.0	1400	2560	80	38	960	84	38
208 (1)	PAEC4015A-NA	7514.00	-	4.5	1950	2560	81	58	1470	108	49
208 (1)	PAEC4020A-NA	10028.00	-	6.0	2800	2560	82	77	1960	141	64
208 (1)	PAEC4025A-NA	11223.00	-	7.5	3300	2560	83	97	2470	172	78
Recessed											
Electric heat											
600 (3)	AREC4010E12-600VNA	9693.00	4/12	15	1530	2220	76	38	960	125	56.5
600 (3)	AREC4015E18-600VNA	10465.00	6/18	22	2150	2220	76	59	1485	171	77.5
600 (3)	AREC4020E24-600VNA	18379.00	8/24	30	3050	2220	78	78	1975	224	101.5
600 (3)	AREC4025E30-600VNA	27389.00	10/30	36	3650	2220	80	98	2508	287	121.0
480 (3)	AREC4010E12-480VNA	9693.00	4/12	19	1530	2220	76	38	960	125	56.5
480 (3)	AREC4015E18-480VNA	10465.00	6/18	26	2150	2220	76	59	1485	171	77.5
480 (3)	AREC4020E24-480VNA	18379.00	8/24	35	3050	2220	78	78	1975	224	101.5
480 (3)	AREC4025E30-480VNA	27548.00	10/30	43	3650	2220	80	98	2508	287	121.0
208 (3)	AREC4010E10-208VNA	9406.00	4/10	31	1530	2220	76	38	960	117	53.0
208 (3)	AREC4015E15-208VNA	10179.00	5/15	44	2150	2220	76	59	1485	163	74.0
208 (3)	AREC4020E20-208VNA	18521.00	7/20	60	3050	2220	78	78	1975	212	96.0
No heat											
208 (1)	AREC4010A-NA	8094.00	-	3.1	1530	2220	76	38	960	99	52
208 (1)	AREC4015A-NA	8845.00	-	3.9	2150	2220	76	59	1485	139	71
208 (1)	AREC4020A-NA	14670.00	-	6.2	3050	2220	78	78	1975	181	94
208 (1)	AREC4025A-NA	19985.00	-	7.0	3650	2220	80	98	2508	234	121

To order any custom colors from the R.A.L. chart, add "SP" at the end of the Product # and specify RAL color # on the order. Contact our customer service department for lead times.

¹ Measurements according to AMCA 220-05. Average values for products in the series. Measurement taken at 0.3 ft. (0.1 m).

² Values shown are for total sound power levels for Installation Type A: free inlet, free outlet. The Sound power level ratings shown are in decibels, referred to 10-12 watts, calculated per AMCA Standard 301.

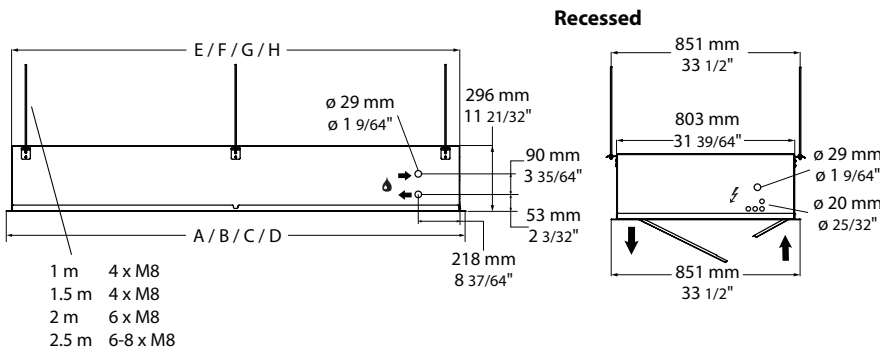

ORA-EC40

Options for horizontal mounting

Product # Kit	Price	Description	Quantity included	Dimension	
				in.	mm
PA34WB15	162.00	Wall mounting brackets for 1 and 1.5 m (3.3 and 4.9 ft.) units	2	16	400
PA34WB20	243.00	Wall mounting brackets for 2 m (6.6 ft.) units	3	16	400
PA34WB30	324.00	Wall mounting brackets for 2.5 m (8.2 ft.) units	4	16	400
PA34VD15	61.00	Vibration dampers for 1 and 1.5 m (3.3 and 4.9 ft.) units	4	-	-
PA34VD20	89.00	Vibration dampers for 2 m (6.6 ft.) units	6	-	-
PA34VD30	127.00	Vibration dampers for 2.5 m (8.2 ft.) units	8	-	-
PA4JK	511.00	Joining and vertical mounting kit PAEC4000	1	-	-
PA4DW10	970.00	Design kit for wall and vertical mounting PAEC4010x	1	3 27/64 x 16 11/16 x 39 39/64	87 x 424 x 1006
PA4DW15	1090.00	Design kit for wall and vertical mounting PAEC4015x	1	3 27/64 x 16 11/16 x 59 11/16	87 x 424 x 1516
PA4DW20	1179.00	Design kit for wall and vertical mounting PAEC4020x	1	3 27/64 x 16 11/16 x 78 31/32	87 x 424 x 2006
PA4DW25	1293.00	Design kit for wall and vertical mounting PAEC4025x	1	3 27/64 x 16 11/16 x 99 1/16	87 x 424 x 2516
PA4DCS	926.00	Design kit for ceiling mounting, small	1	8 - 12	200 - 300
PA4DCM	965.00	Design kit for ceiling mounting, medium	1	12 - 20	300 - 500
PA4DCL	1060.00	Design kit for ceiling mounting, large	1	20 - 36	500 - 900
PA4DXT	475.00	Design kit for ceiling mounting, extension	1	16 17/32	420

Options for vertical mounting

Product # Kit	Price	Description	Quantity included
PA4JK	511.00	Joining and vertical mounting kit PAEC4000	1
PA4DW10	970.00	Design kit for wall and vertical mounting PAEC4010x	1
PA4DW15	1090.00	Design kit for wall and vertical mounting PAEC4015x	1
PA4DW20	1179.00	Design kit for wall and vertical mounting PAEC4020x	1
PA4DW25	1293.00	Design kit for wall and vertical mounting PAEC4025x	1
AXP300	475.00	Collision protection	1

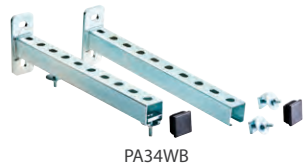

Surface - Horizontal mounting

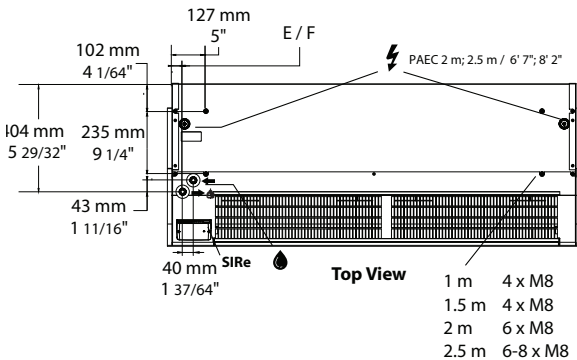
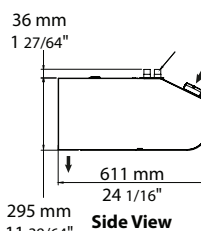
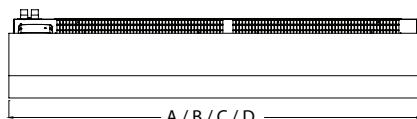

	mm	in.	Type
A	1039	40 29/32	PAEC4010x
B	1549	60 63/64	PAEC4015x
C	2039	80 9/32	PAEC4020x
D	2549	100 23/64	PAEC4025x
E	40	1 37/64	PAEC4010/15/20x
F	39	1 17/32	PAEC4025x
G	1572	61 57/64	PAEC4015x
H	2062	81 3/16	PAEC4020x
I	2572	101 17/64	PAEC4025x
J	1515	59 41/64	PAEC4015x
K	2004	78 57/64	PAEC4020x
L	2515	99 1/64	PAEC4025x

Surface - Vertical mounting

